



Warnung

Lebensgefahr durch elektrische Spannung!
 Lesen Sie die Bedienungsanleitung, vor Beginn der Installationsarbeiten.
 Alle Installationsarbeiten sind in spannungsfreiem Zustand durchzuführen.

Warning

Electrical voltage! Danger to life!
 Read operating manual before starting installation work.
 All installation work must be performed under the absence of voltage.

Avertissement

Danger de mort par tension électrique!
 Lisez le manuel d'utilisation avant de commencer les travaux d'installation.
 Tous les travaux d'installation doivent être exécutés en l'absence de tension.

Waarschuwing

Levensgevaar door elektrische spanning
 Lees de instructies voordat u begint met de installatie.
 Alle installatiewerkzaamheden dienen uitgevoerd te worden in spanningsvrije toestand.

Avvertenza

Pericolo di morte dovuto alla presenza di tensione elettrica
 Leggere attentamente le istruzioni prima di iniziare il lavoro di installazione.
 Tutte le operazioni di installazione devono essere eseguite in assenza di tensione.

Peligro

Peligro de muerte por tensión eléctrica.
 Lea las instrucciones de servicio antes de empezar los trabajos de instalación.
 Todos los trabajos se tienen que realizar sin tensión.

DEU

ENG

FRA

NDL

ITA

ESP

► Lieferumfang / Scope of supply / Etendue de fourniture / Leveringsomvang / Volume di fornitura / Contenido del envío

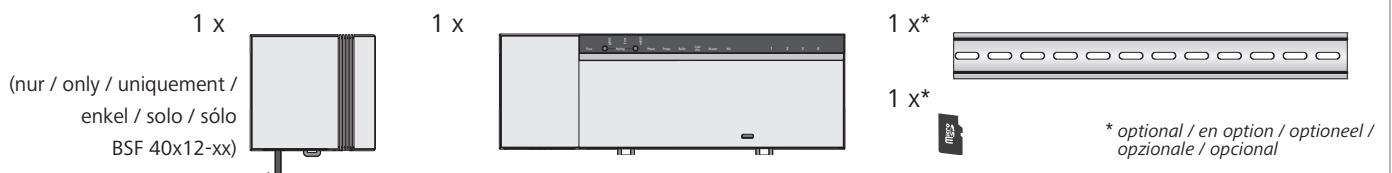

► Installation / Installatie / Installazione / Instalación

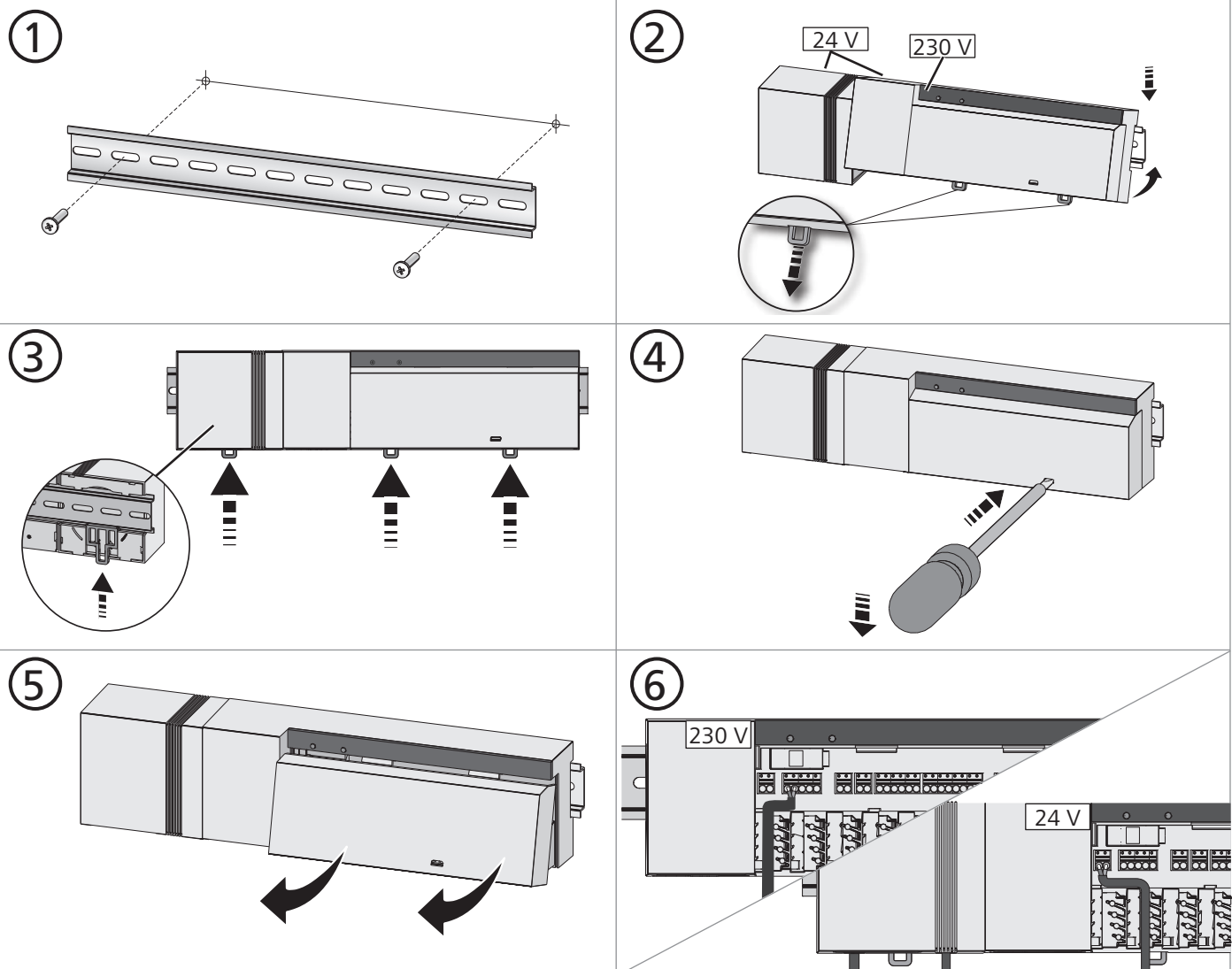

► 230 V: Elektrischer Anschluss / Electric connection / Branchement électrique / Elektrische aansluiting / Collegamento elettrico / Conexión eléctrica

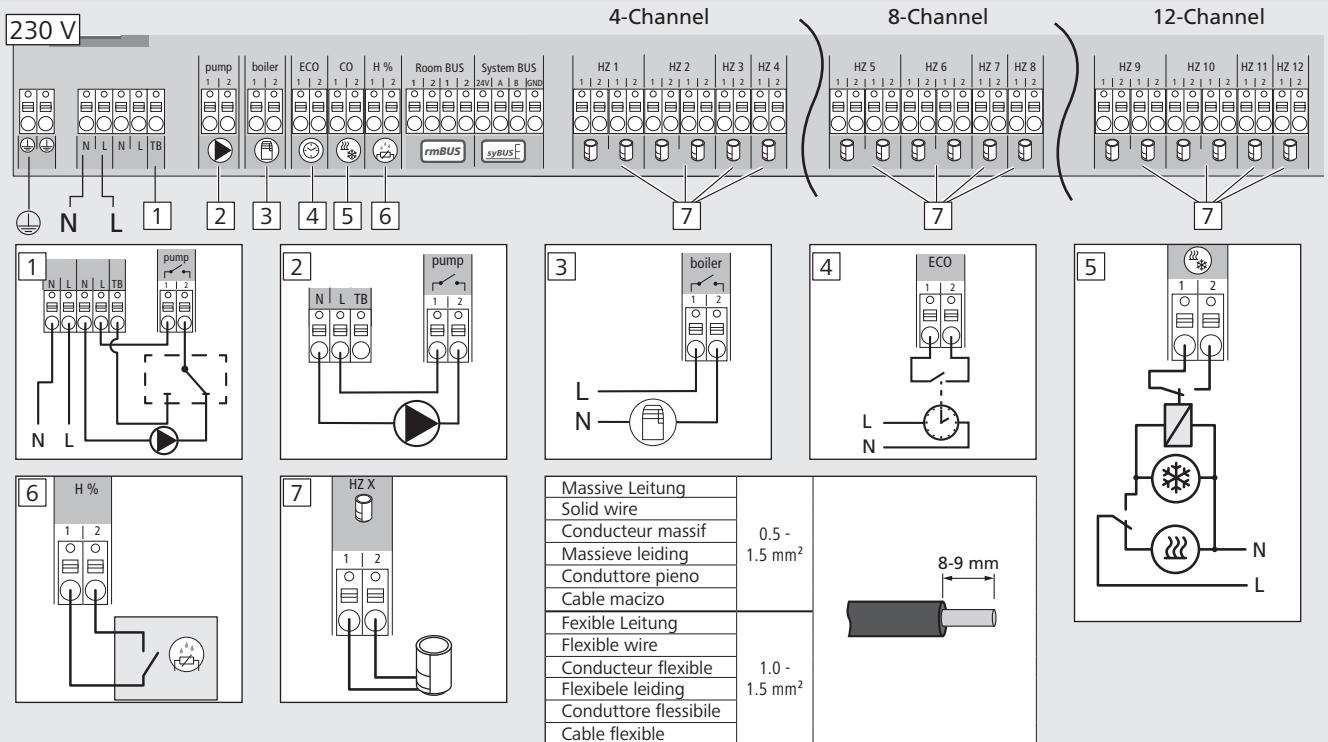

► 24 V: Elektrischer Anschluss / Electric connection / Branchement électrique / Elektrische aansluiting / Collegamento elettrico / Conexión eléctrica

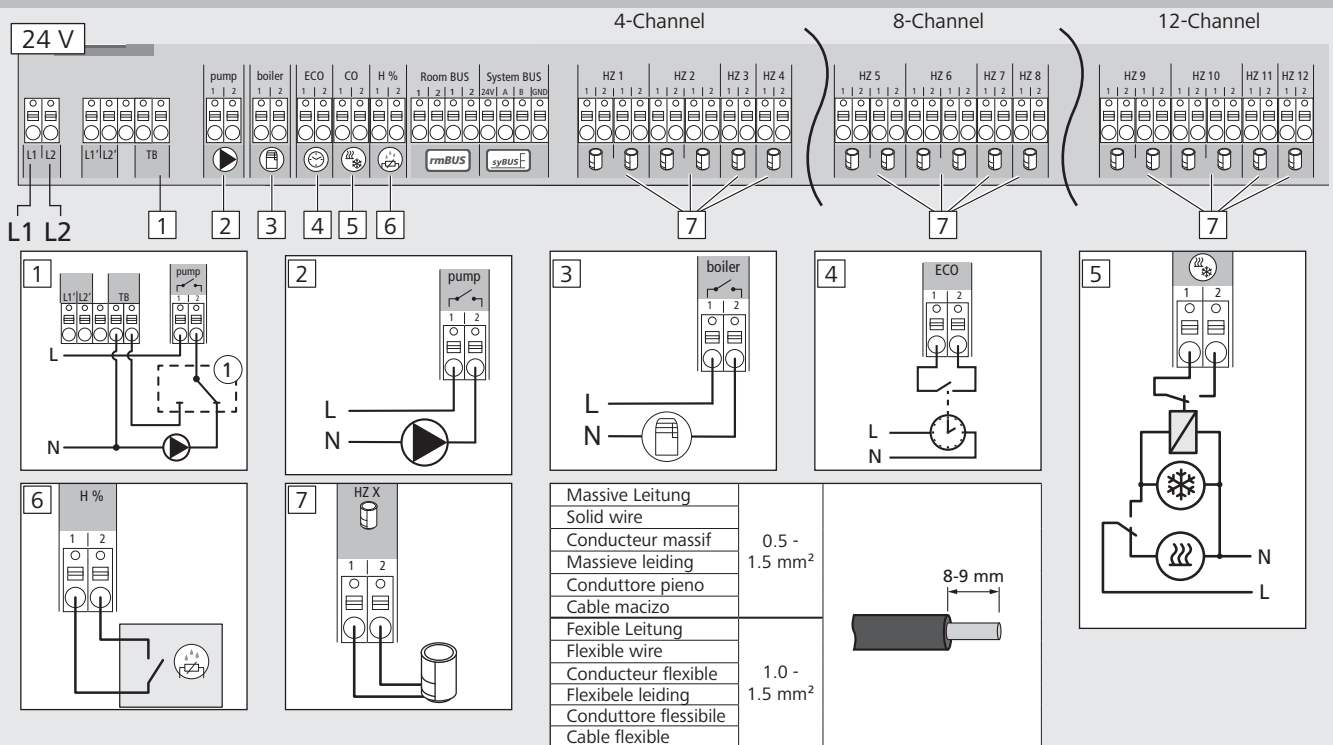

DEU

ENG

FRA

NDL

ITA

ESP

1	Temperaturbegrenzer	Temperature limiter	Limiteur de température	Temperatuurbegrenzer	Limitatore di temperatura	Limitador de la temperatura
2	Pumpe	Pump	Pompe	Pomp	Pompa	Bomba
3	Kessel	Boiler	Chaudière	Ketel	Caldaia	Caldera
4	ECO	ECO	ECO	ECO	ECO	ECO
5	Change Over	Change over	Change-over	Change Over	Change Over	Change Over (conmutación)
6	Taupunktsensor	Dew point sensor	Capteur du point de rosée	Dauwpunktsensor	Sensore del punto di rugiada	Sensor del punto de rocío
7	Stellantriebe	Actuators	Actionneurs	Stelaandrijvingen	Attuatori	Mandos de accionamiento

DEU
ENG
FRA
NDL
ITA
ESP

► Anschluss Room Bus und System Bus / Connection of Room Bus and System Bus / Raccordement Room Bus et System Bus / Aansluiting Room Bus en System Bus / Collegamento Room Bus e System Bus / Conexión Room Bus y System Bus

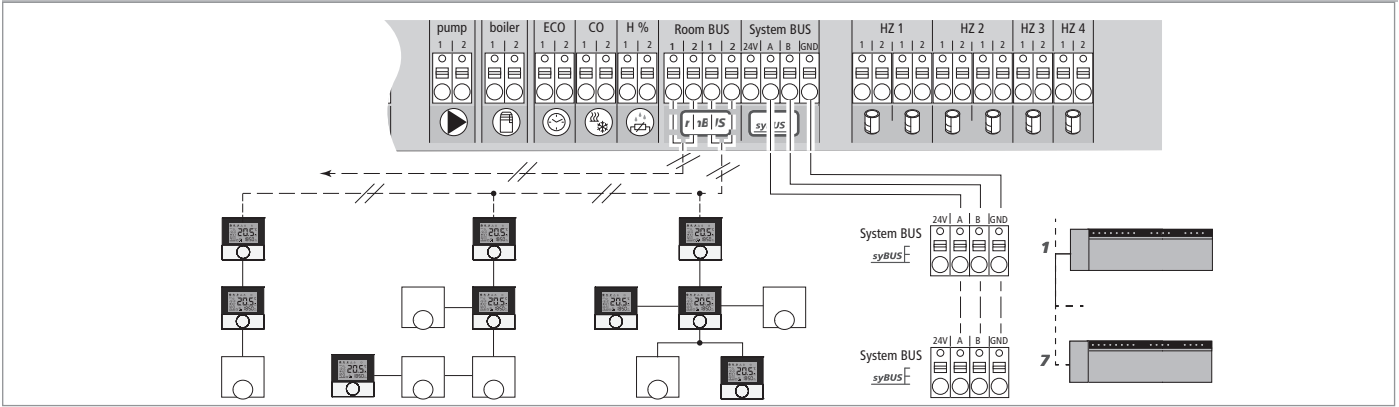

► Installation / Installatie / Installazione / Instalación

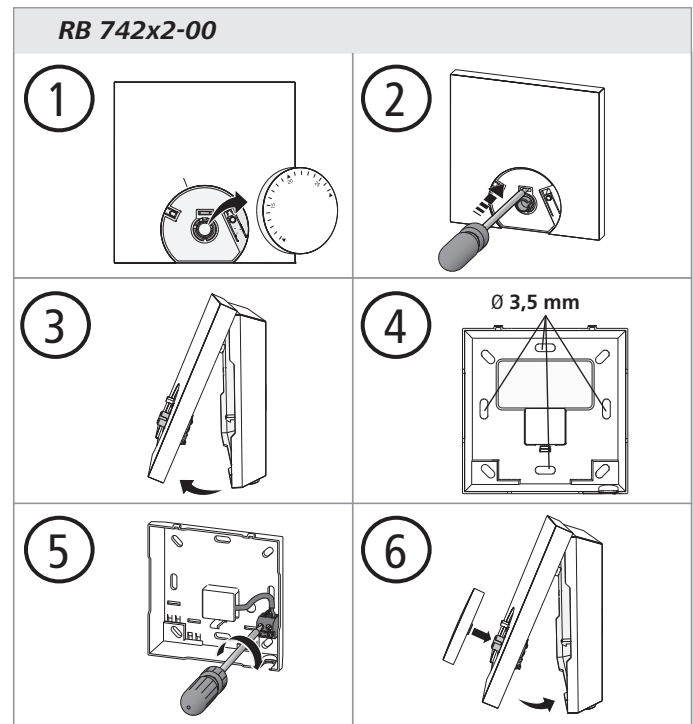
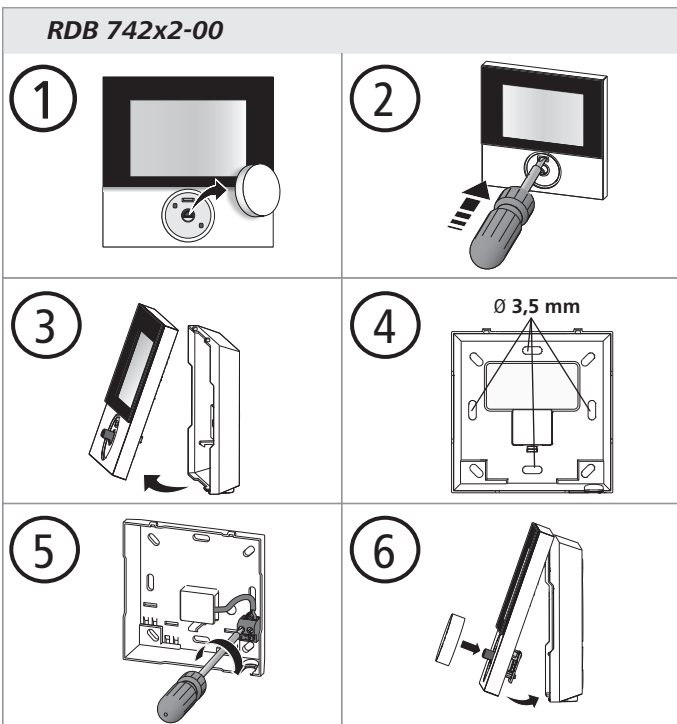
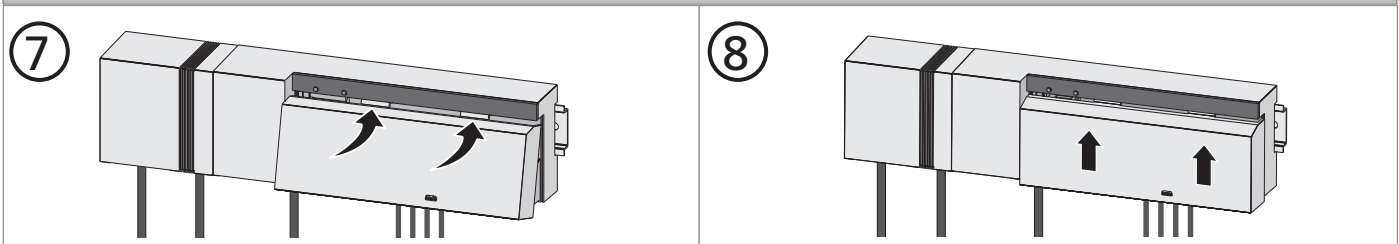

DEU
ENG
FRA
NDL
ITA
ESP

► **Erstinbetriebnahme / First commissioning / Première mise en Service / Eerste inbedrijfstelling / Prima messa in servizio / Puesta en funcionamiento por primera vez**

1

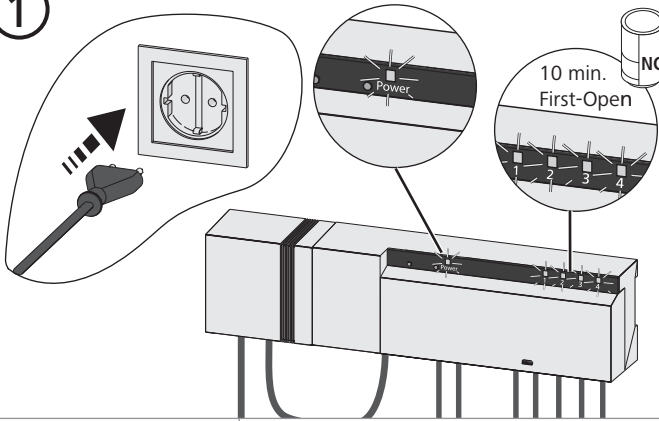

2

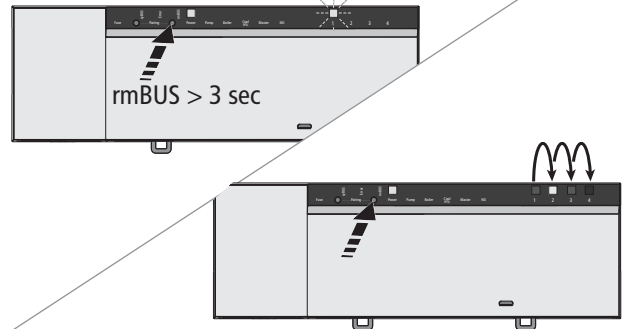

3a

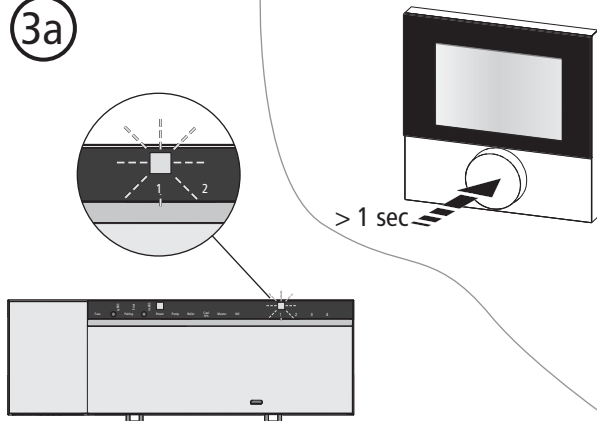

3b

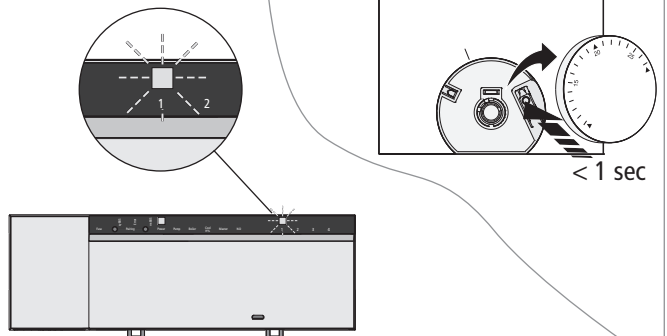

► **Anschlüsse / Connections / Connecteurs / Aansluitingen / Collegamenti / Conexiones**

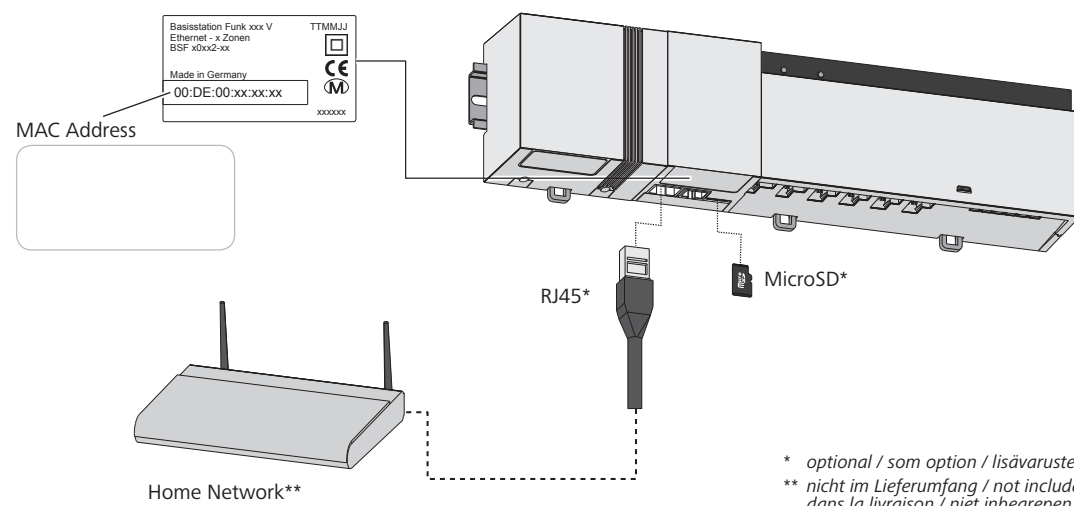

* optional / som option / lisävarusteinen / tillval / w opcji / опционально
 ** nicht im Lieferumfang / not included in the scope of delivery / non inclus dans la livraison / niet inbegrepen in de levering / non compreso nella dotazione di forniture / no incluido en el volumen de suministro

► **Bedienungsanleitung / Operating instructions / Mode d'emploi / Operatie instructies / Istruzioni per l'uso / Manual del usuario**



www.ezr-home.de

Made in Germany

